

Butterfly Valves

Application:	Butterfly valves are commonly used on dry bulk tankers to control the flow of product; designed to be placed between 2 ASME/ANSI 125 or 150 lb. flanges.
Materials:	Aluminum bodies with iron or stainless-steel disc, polymer bushings, Buna-N (Nitrile) seals and seats, spring, stem and locking lever pin are stainless-steel, aluminum handle and throttling plate.
Features & Benefits:	<ul style="list-style-type: none"> • Rugged cast aluminum • Flange gaskets are not required; the valves elastomer seat also doubles as the flange gasket. • Handles are high strength 713 aluminum, with a retrogressive re-aging process which creates as stronger handle than the cast iron handle which are commonly used in the industry • Iron or stainless discs are standard for superior wear resistance • FDA approved black or white Buna-N seals, -20°F to 275°F (-29°C to 135°C)

Butterfly Valve Dimensions

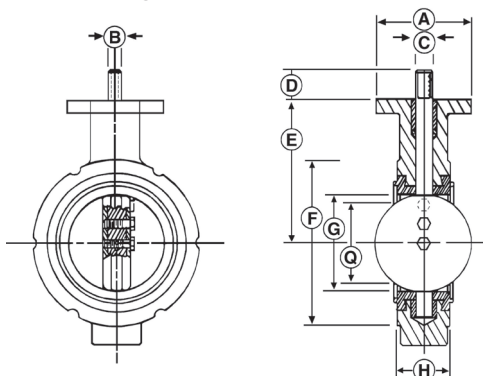

Size	A	B	C	D	E	F	G	H	Q	Weight (lbs.)
2"	4.000	0.375	0.563	1.250	3.938	4.125	2.125	1.625	1.688	3
3"	4.000	0.375	0.563	1.250	4.875	5.375	3.125	1.750	2.875	5
4"	4.000	0.438	0.625	1.250	6.000	6.875	4.125	2.000	3.875	8
5"	4.000	0.438	0.625	1.250	6.000	7.625	5.188	2.125	5.000	9
6"	4.000	0.438	0.625	1.250	6.625	8.750	6.125	2.125	6.000	9
8"	6.000	0.500	0.750	1.250	8.313	11.000	8.125	2.500	8.000	--
10"	6.000	0.625	0.875	1.250	9.125	13.375	10.125	2.500	10.000	--

- All dimensions are given in inches
- "Q" dimension is the minimum allowable inside diameter of the pipe or mating flange

One-Piece Aluminum Body with Iron Disc and Black Buna-N Seals



DB4-400-1500



4-480-1500

With Integrated Notch Plate

Size	Description	Complete Valve Part # ¹
2"	125/150# flange	2-400-1500
3"	125/150# flange	DB3-400-1500
4"	125/150# flange	DB4-400-1500
4"	TTMA	4A-400-1500
5"	125/150# flange	DB5-400-1500
6"	125/150# flange	DB6-400-1500
8"	125/150# flange	8-400-1500
10"	125/150# flange	10-400-1500

Size	Description	Complete Valve Part # ¹
4"	125/150# flange	4-480-1500
4"	TTMA	4A-480-1500
5"	125/150# flange	5-480-1500
6"	125/150# flange	6-480-1500

¹ Handle kits are sold separately on Page 17.