

wire reinforced, nondeforming suction hose

Custom SUCTION SERVICE HOSE

Salem-Republic Suction Hose can be made with a variety of high grade tube material. These feature abrasion and cut resistant premium grade rubber lining to withstand the destructive action of sand and gravel from quarries and beaches, rock and sludge from channels and harbors, coral from the sea.

In addition to the wire helix found close to the thick tube, multi-ply of polyester, nylon or cotton duck fabrics are used to reinforce the hose carcass to form an extra-heavy wall that absorbs shock and vibration between cutter head and pump. (These hoses can be custom-engineered to provide the bend radius you need.)

SRR's Suction Hose is supplied with a number of cover choices, including SBR, EPDM or neoprene, to meet your most exacting need for wear resistance and protection from sunlight and ozone.

Custom Tube Linings — are supplied to customer needs and are made of the highest quality custom blends of natural and synthetic rubber.

SRR Carcass — Reinforced suction hose takes positive pressure for safe, efficient back-flushing to dislodge obstructions.

Finest Quality Rubber Cover — Assures high tear- and abrasion-resistance.

Bias — Multi-ply synthetic fabrics assure maximum tensile strength and ability to absorb shock and vibration.

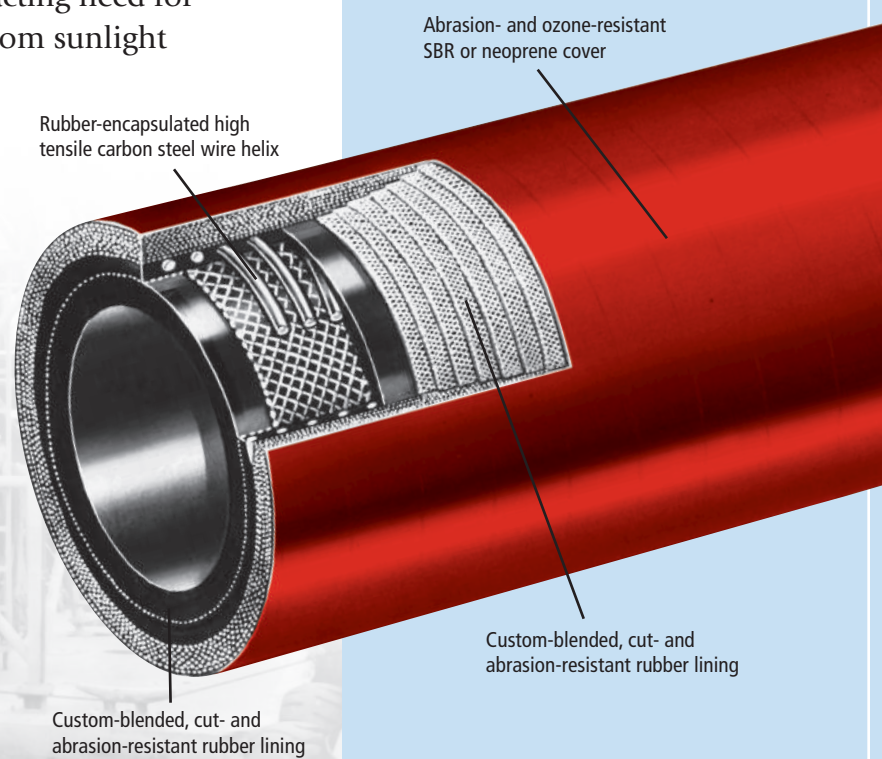

Suction/discharge hoses, 16-in. I.D., used on barge-unloading dredge. Hoses feature hard-wall suction construction

Dredge Pipe SLEEVES

SRR's Dredge Sleeves are unsurpassed for quality and stability. SRR sleeves will not expand under pressure causing clamps to loosen.

The same high-quality custom-blended compounds found in SRR's suction and discharge hoses are used in SRR's dredge sleeves.

Salem-Republic does not use a ply "rating" system. The number of plies stated for any size are by actual count.

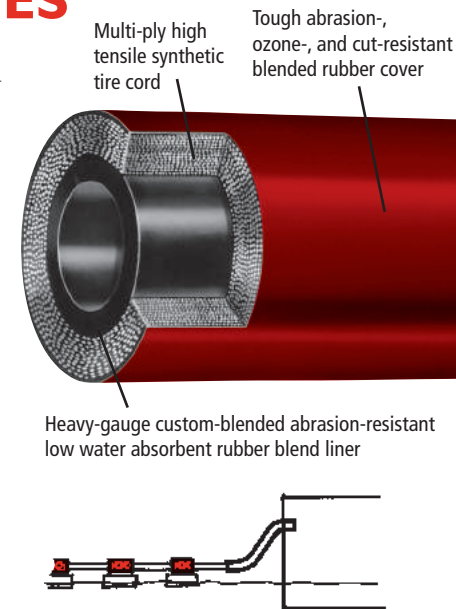

GIMBAL joint hose

SRR Gimbal Joint Suction Hoses are used with universal joints or gimbals which constrain hose movement in two planes. This provides controlled bending with problems of overstressing eliminated.

Available in up to 42-in. I.D., the Gimbal-type hose features imbedded welded steel rings for maximum compressive strength and flexibility.

The smooth bore design features use of highest quality rubber lining, resistant to abrasion and cuts. Heavy duty covers of SBR, EPDM, or neoprene can be provided for resistance to sunlight, saltwater, and oil.

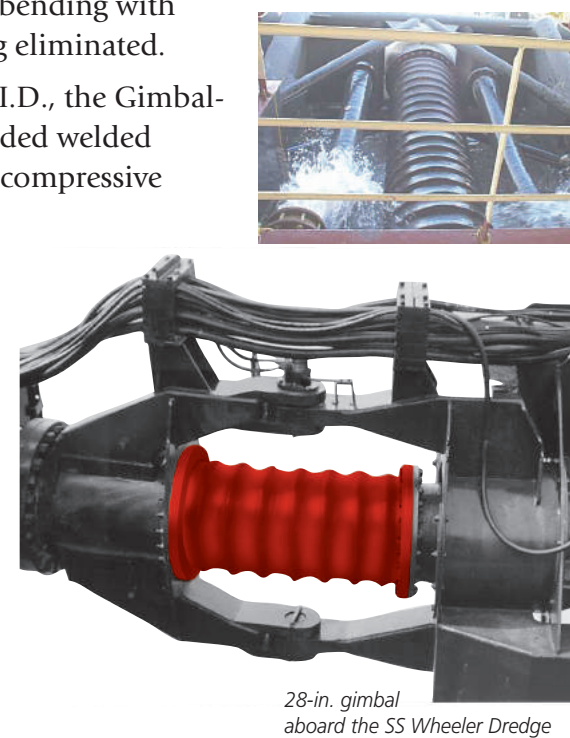

28-in. gimbal aboard the SS Wheeler Dredge

Distributed by _____

Optional End Constructions

Hose ends shown below meet the widest variety of service and budget needs. * Where possible, hose terminations should use nipples that are the same I.D. as the hose to minimize turbulence and accelerated wear.

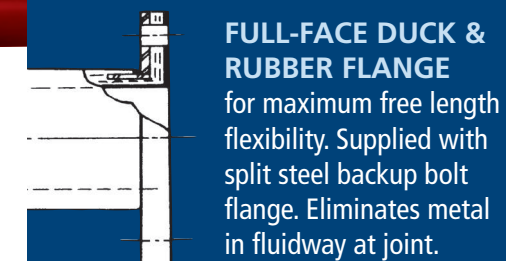

FULL-FACE DUCK & RUBBER FLANGE for maximum free length flexibility. Supplied with split steel backup bolt flange. Eliminates metal in fluidway at joint.

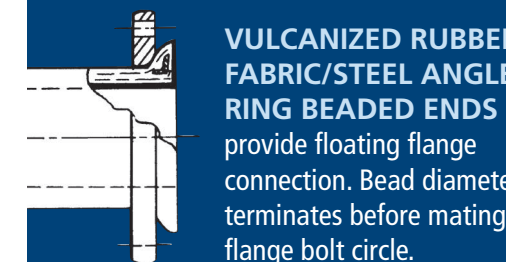

VULCANIZED RUBBER/FABRIC/STEEL ANGLE RING BEADED ENDS provide floating flange connection. Bead diameter terminates before mating flange bolt circle.

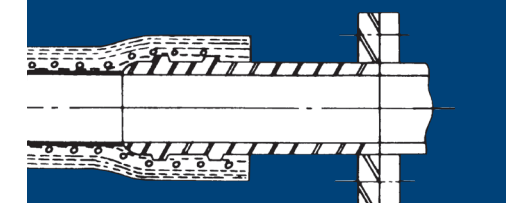

BUILT-IN STEEL NIPPLE provides most secure fitting possible. Nipple I.D. matches hose I.D., allowing full flow to minimize turbulence and pressure drop.

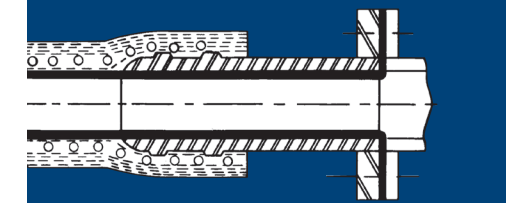

RUBBER-LINED STEEL NIPPLE provides extended service by protecting the steel nipple from wear and corrosion.

SIR salem-republic rubber company

CUSTOM ENGINEERED DREDGING SOLUTIONS

SUCTION • DISCHARGE • SLEEVES • GIMBALS



Dan Holt
Hose Building
Specialist

Marshall Ney

"One day I hope to carry on the tradition of excellence set by my father and grandfather—leading the industry in custom hand-made hoses for 40 years, and counting."

*Front cover shows a 42" ID Dredge Discharge Hose

Foremost Large-Bore Dredge Hose Manufacturer in America!



CUSTOM ENGINEERED, HANDMADE DREDGE HOSE...Designed and built for survival from abrasive wear and abusive handling

Salem-Republic's Dredging Hose

features "customized" heavy-duty, wear-resistant constructions employing the finest grades of natural and synthetic rubber and fabric. Produced in hard-and soft-wall constructions, SRR's premium Dredging Hose is the product of many years of experience in handmade hose design and manufacturing.

SRR engineers and manufactures the complete hose assembly from formulation of all rubber compounds to vulcanizing the finished hose. This is your assurance that all raw materials used in production are compatible with each other and most suitable for the intended use of the hose.

If your requirements include flexibility, stability, vibration damping or resistance to abusive handling, special ends or no ends at all...call Salem-Republic Rubber Company.

SUCTION

SRR's tough hard suction hose features a custom-blended rubber lining that resists the most severe cutting and abrasive action. Spring steel helix wire with multiple synthetic textile reinforcement provides for full vacuum, kink resistance, and vibration damping.

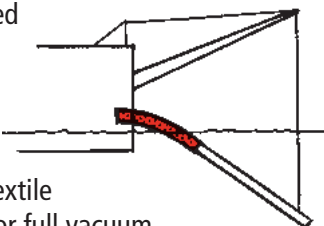

DISCHARGE

Hard-wall (SDH) and soft-wall (SDS) stern discharge hose are designed to meet your needs. Hard-wall where bend radius is controlled... Soft-wall where kinking is unavoidable.

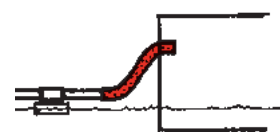

SLEEVE—Only the best...SRR's unique construction includes use of nonwicking...high tensile synthetic tire cord. No "ply ratings"...the number of plies stated is actual count. (see back cover)

GIMBALS—Specifically designed to exacting specification for individual dragarm hopper dredges. (see back cover)

SDH Hard-Wall DISCHARGE HOSE

SRR's SDH Hard-Wall Discharge Hose employs a wire helix with multi-ply reinforcing fabric. The helix construction, which also permits use for suction service, offers the dredge operator a discharge hose that stays round through normal bend radii. This affords extended service life over soft-wall hose, which is susceptible to ovaling out. Operating pressures up to 400psi are standard with a 4:1 safety factor.

Available with numerous options, including special diameters, lengths, and cover materials, SRR's SDH Hard-Wall Discharge Hose helps to reduce dredge downtime by minimizing maintenance problems.

Optional Tube Lining Thickness — to meet special needs of materials being handled, hose diameter, and service conditions. SRR's compounds are formulated to resist abrasion and cutting.

Custom Cover — supplied with wear-resistant SBR, EPDM or neoprene for added resistance to ozone and sunlight.

Custom Lengths — to 50 ft., diameters to match pipe I.D.'s or O.D.'s up to 42".

Custom Ends — straight or enlarged to fit your pipe size or any of the flanged ends shown on back page.

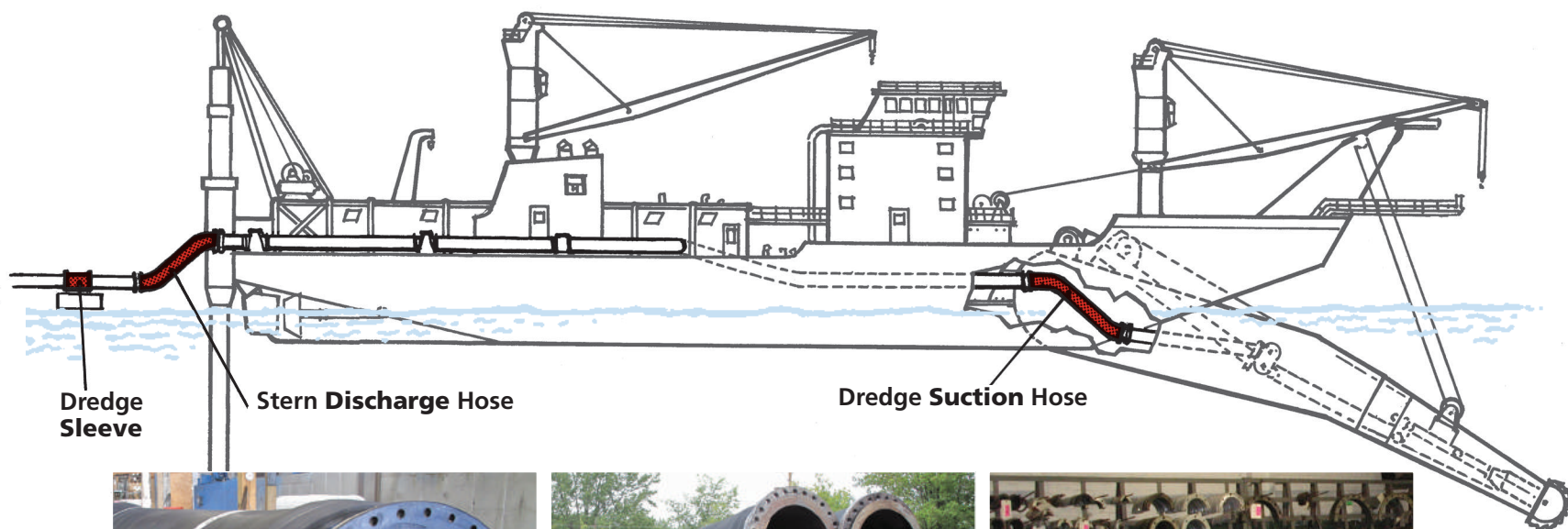

(Above) Barge-unloading dredge using twin suction/discharge hoses.

(Below) Cutter head suction dredge with SRR Dredge Suction hose

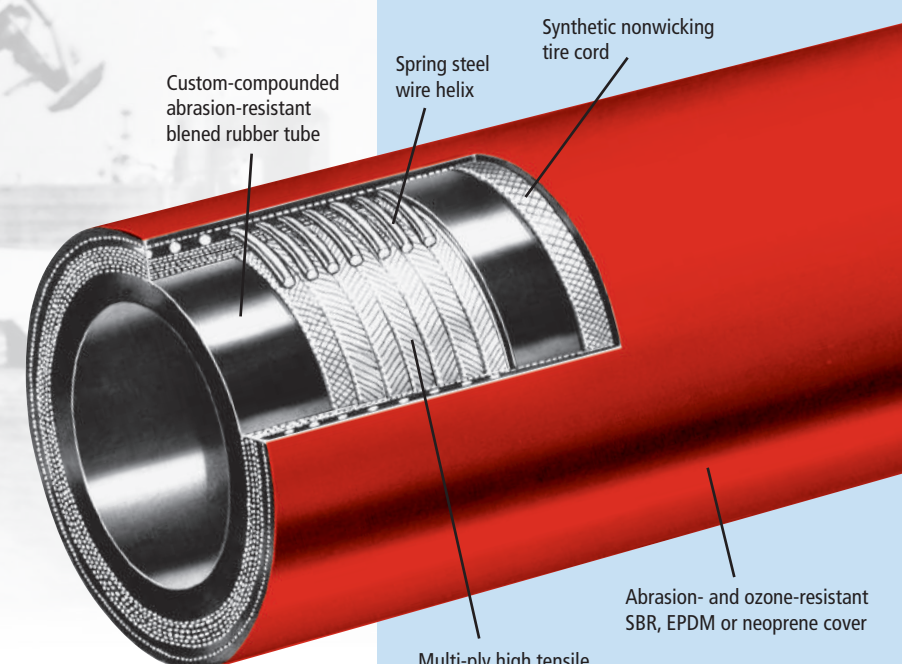

Labels for SDH diagram: Custom-compounded abrasion-resistant blended rubber tube, Spring steel wire helix, Synthetic nonwicking tire cord, Multi-ply high tensile tire cord, Abrasion- and ozone-resistant SBR, EPDM or neoprene cover.

SDS Soft-Wall DISCHARGE HOSE

The SDS Dredge Discharge hose is designed for operating pressure up to 400psi. The SDS hoses are handmade and can be provided with flanged ends, enlarged ends (to easily slip over pipe stubs), or plain cut ends.

Soft-Wall Discharge Hose is intended for service when tides, current or operating conditions may cause kinking, which quickly destroys hard-wall hose. Applying pressure to a kinked soft-wall hose will round out the hose with no detrimental effect.

Soft-Wall Construction — Recommended for use where hose kinking can otherwise cause premature failure. SRR soft-wall discharge hose will oval out, but springs back under working pressure.

Hose Cover — SBR rubber, EPDM or neoprene is available to meet custom requirements for cut and abrasion resistance, and to withstand strong sunlight and ozone. SRR will provide a tough neoprene cover for salt-water service, and where it will be exposed to long periods of sunlight.

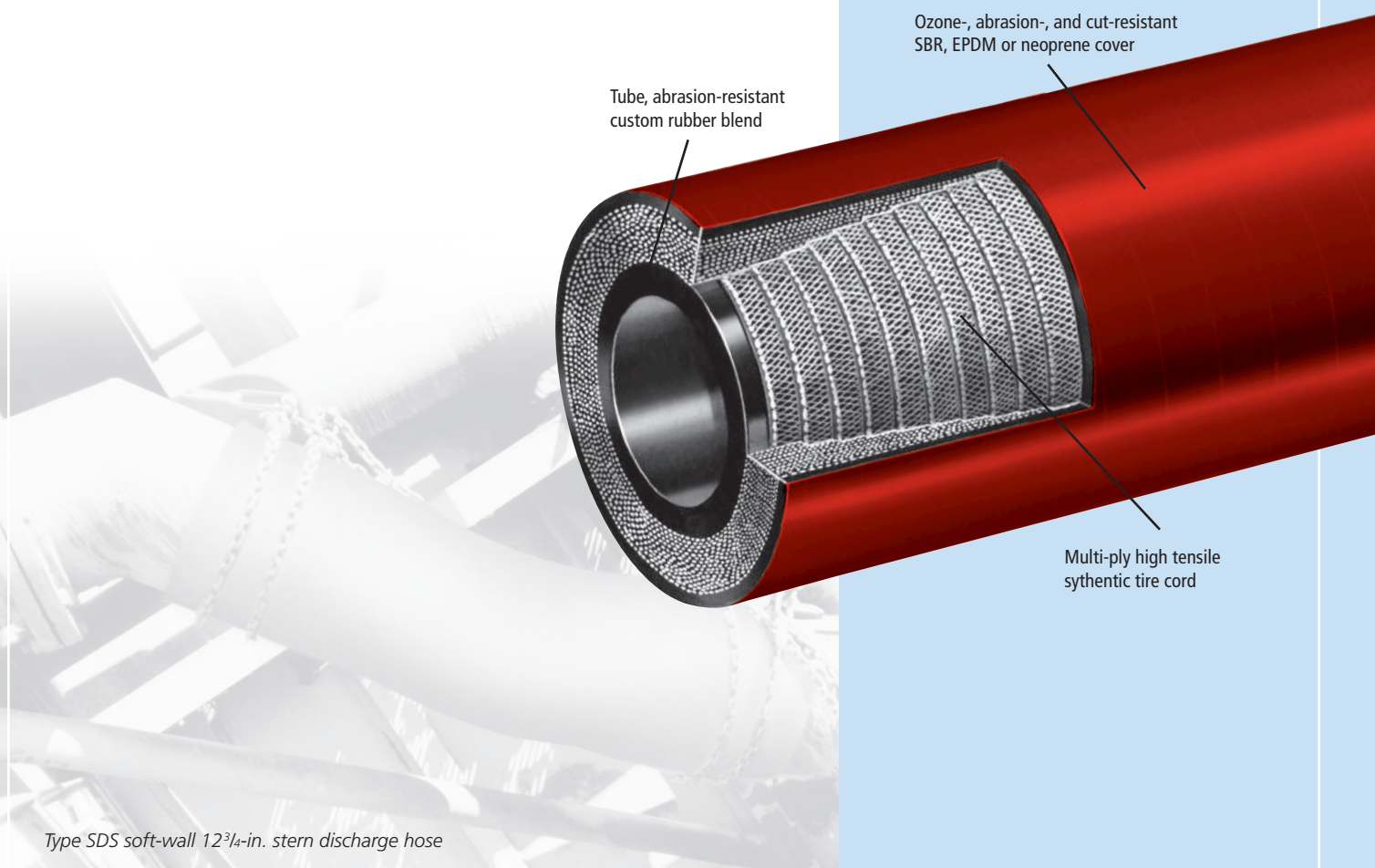

Type SDS soft-wall 12 3/4-in. stern discharge hose

Made in the USA