



DISPENSERS



PUMPS



METERS



METERED NOZZLES



NOZZLES

SUZZARABLUE MANUAL NOZZLE

FEATURES

- **READY TO USE**
- **ERGONOMIC HANDLE**
- **LIGHTWEIGHT**

The Piusi SUZZARABLUE MANUAL NOZZLE is the basic version of Suzzarablu nozzles designed to dispense DEF. Among the manual devices, it is distinguished by its high efficiency thanks to the a flow resistance, and a very economic construction.

PERFORMANCE

UP TO

20 GPM

FLOW RATE

50 PSI

PRESSURE



SUZZARABLUE MANUAL NOZZLE



PACKAGING

PART #	WEIGHT		PACKAGING		
	KG	LBS	MM	INCH	PCS/BOX
F14761000	0.2	0.4	800X480X300	31.5X18.9X11.8	1



FILTRATION



FLUID MONITORING



HOSE REELS



ACCESSORIES



AIR



ANTIFREEZE



DEF



BIODIESEL



DIESEL



FOOD



GASOLINE



GREASE



KEROSENE



OIL



WATER



WINDSCREEN

CHARTS

SUZZARABLUE MANUAL NOZZLE

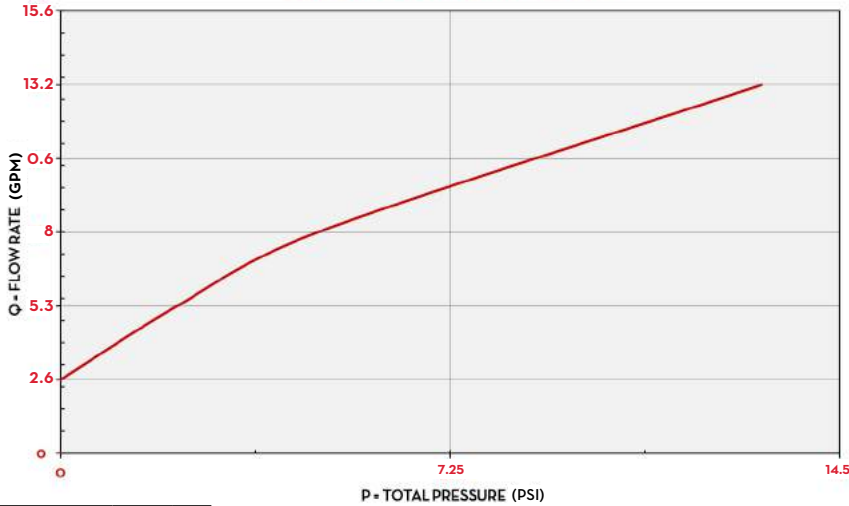

TYPE OF FLUID	WATER
TEMPERATURE	68 °F

IN THE BOX

- SUZZARABLUE MANUAL NOZZLE
- INSTRUCTION MANUAL

DETAILS



STAINLESS STEEL SPOUT

DIMENSIONS

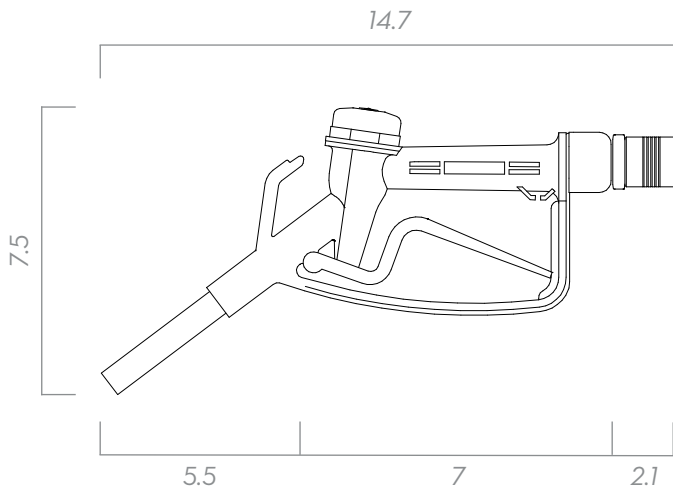

Dimensions expressed in inches

MATERIALS

- BODY: TECHNOPYLIMER
- SPOUT: STAINLESS STEEL

TECHNICAL DATA

PART #	DESCRIPTION	FLUIDS TYPE	FLOW RATE		PRESSURE	INLET	SWIVEL	SPOUT
			L/MIN	GPM				
F14761000	DEF MANUAL NOZZLE W/HOSE TAIL W/OUT LOCK		80	20	50	3/4"	NO	3/4"

SUZZARABLUE MANUAL NOZZLE



NOZZLES ACCESSORIES

AUTOMATIC NOZZLES

SB325_X	PART #	DESCRIPTION
	F19174000	SB325 MISFILL SPOUT W/ BYPASS ADAPTOR
	R19172000	SB325 REPLACEMENT MIS-FILL SPOUT
	R1917300A	SB325 REPLACEMENT AUTO SPOUT
	F18400000	SB325 MAGNETIC BYPASS ADAPTOR (RED)
	F15165000	MAGNETIC TANK ADAPTOR FOR MIS-FILL SPOUT



SUZZARBLUE A60	PART #	DESCRIPTION
	F15165000	MAGNETIC TANK ADAPTOR FOR MIS-FILL SPOUT
	F16475000	ADAPTOR K24 TO AUTO 3/4" BSP-M TO 1" BSP-F



MANUAL NOZZLES

SUZZARBLUE MANUAL NOZZLE	PART #	DESCRIPTION
	F15776000	SWIVEL 1" BSP-M/F PLASTIC MANUAL NOZZLE

