



DISPENSERS



PUMPS



METERS



METERED NOZZLES



NOZZLES

# ROTARY HAND PUMP

## FEATURES

- **STURDY CONNECTOR**
- **HEAVY DUTY LEVER**
- **HIGH EFFICIENCY**
- **ADJUSTABLE SUCTION PIPE**
- **SELECTED MATERIALS**
- **BUILT-IN NON-RETURN VALVE**

The Piusi HAND PUMP is a rotary vane pump suitable for transferring DEF. Entirely designed, manufactured and certified in Italy, this sturdy pump guarantees a professional performance and is suitable for all drum applications.

## PERFORMANCE

UP TO

**10 GAL**

PER 100 REV

CAPACITY



PIUSI HAND PUMP



## PACKAGING

PART #	WEIGHT		PACKAGING		N. BOXES/EUROPALLET	
	KG	LBS	IN	PCS/BOX		
FOO332A3A	3.2	7	14X10X7	1	50	100
FOO332A80	3.6	8	14X10X7	1	50	100



FILTRATION



FLUID MONITORING



HOSE REELS



ACCESSORIES



AIR



ANTIFREEZE



DEF



BIODIESEL



DIESEL



FOOD



GASOLINE



GREASE



KEROSENE



OIL



WATER



WINDSCREEN

### CHARTS

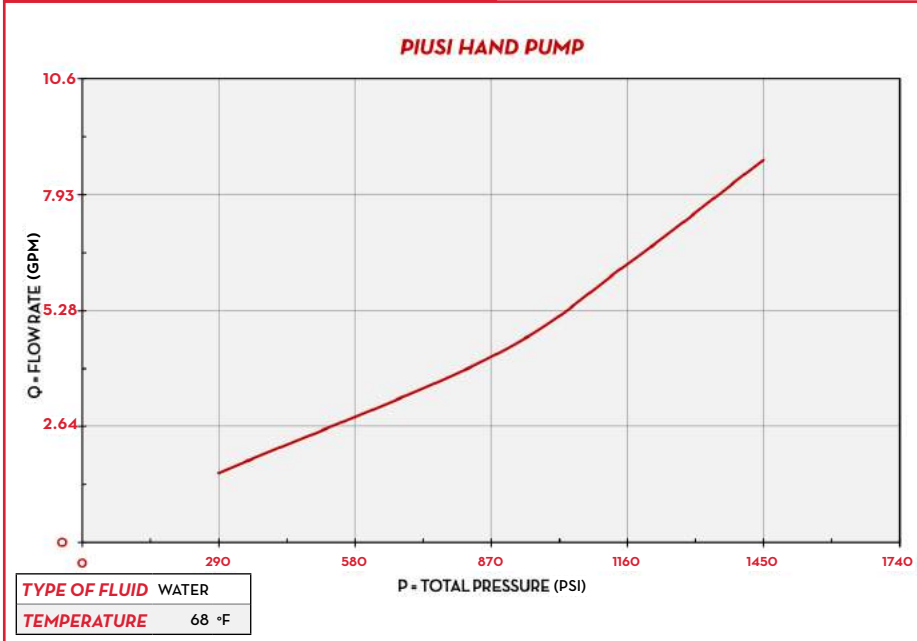

### IN THE BOX

- PIUSI HAND PUMP
- DRUM CONNECTOR
- SUCTION PIPE
- DELIVERY HOSE
- INSTRUCTION MANUAL

### DETAILS



DRUM CONNECTOR Ø2.44"



SUCTION PIPE



STAINLESS STEEL SPOUT

### DIMENSIONS

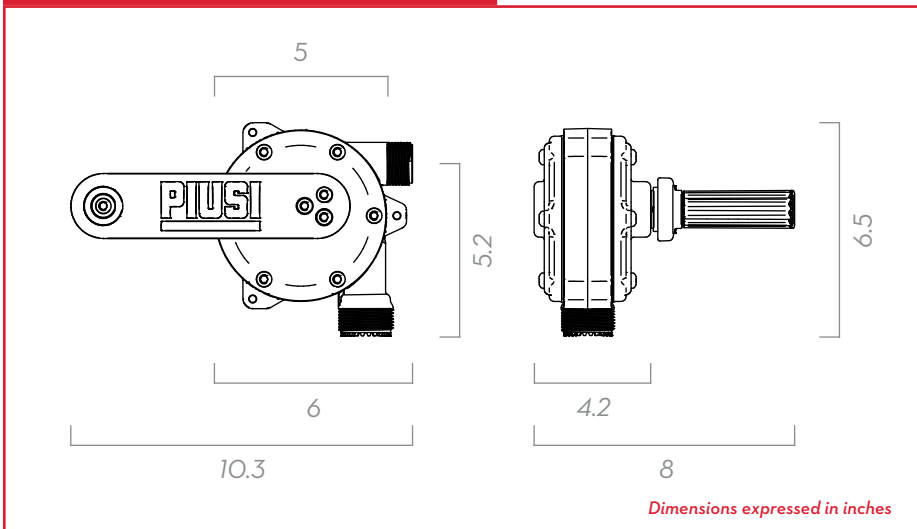

### MATERIALS

- BODY: STAINLESS STEEL, TECHNOPOLYMER
- ROTOR: TECHNOPOLYMER
- VANES: TECHNOPOLYMER

### TECHNICAL DATA

PART #	DESCRIPTION	FLUIDS TYPE	CAPACITY PER 100 REVOLUTIONS		DRUM CONNECTOR	SUCTION TUBE	DELIVERY HOSE LENGTH
			L	USG			FT
FO0332A3A	DEF ROTARY HAND PUMP KIT		38	10	2"/2.4" x 5 buttress	YES	9
FO0332A80	DEF ROTARY HAND PUMP KIT W/ FILTER		38	10	2"/2.4" x 5 buttress	YES	9

## PIUSI HAND PUMP

HAND PUMPS

