



DISPENSERS



PUMPS



METERS



METERED NOZZLES



NOZZLES

MP 140

FEATURES

- IN/OUT INTERCHANGEABLE
- BUILT-IN DIFFUSER
- SUITABLE FOR SUBMERSIBLE INSTALLATION
- HEAVY DUTY
- EASY TO FIT
- STURDY DESIGN

The Piusi MP 140 is a long-lasting pneumatic diaphragm pump suitable for transferring DEF. The small size of this pump allows a wide range of installations, even in severe duty conditions.



MP140

PERFORMANCE

UP TO

26 GPM

FLOW RATE

MAX CAPACITY

20 FT

SELF-PRIMING

MAX

101 PSI

AIR SUPPLY

PRESSURE

MAX

Ø 0.16"

PASSING SOLID



PACKAGING

PART #	WEIGHT		PACKAGING		
	KG	LBS	MM	INCH	PCS/BOX
FOO208P50	5	11	240X380X350	9.4X15X13.8	1



FILTRATION



FLUID MONITORING



HOSE REELS



ACCESSORIES



AIR



ANTIFREEZE



DEF



BIODIESEL



DIESEL



FOOD



GASOLINE



GREASE



KEROSENE



OIL



WATER



WINDSCREEN

CHARTS

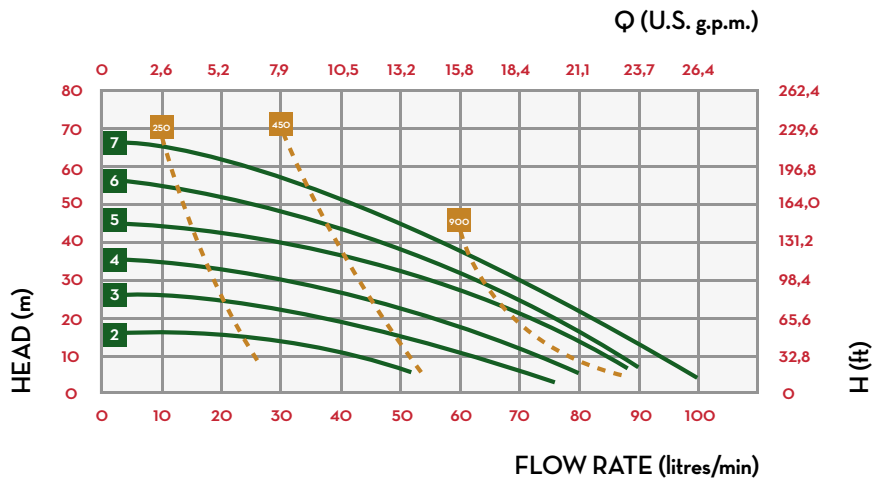

IN THE BOX

- MP PUMP
- INSTRUCTION MANUAL

DETAILS



HEAVY DUTY MATERIALS



TECHNOPOLYMER BODY



STURDY DESIGN

MATERIALS

- BODY: TECHNOPOLYMER
- SIDE PARTS AND COLLECTORS: POLYPROPYLENE
- DIAPHRAGM: EPDM

DIMENSIONS

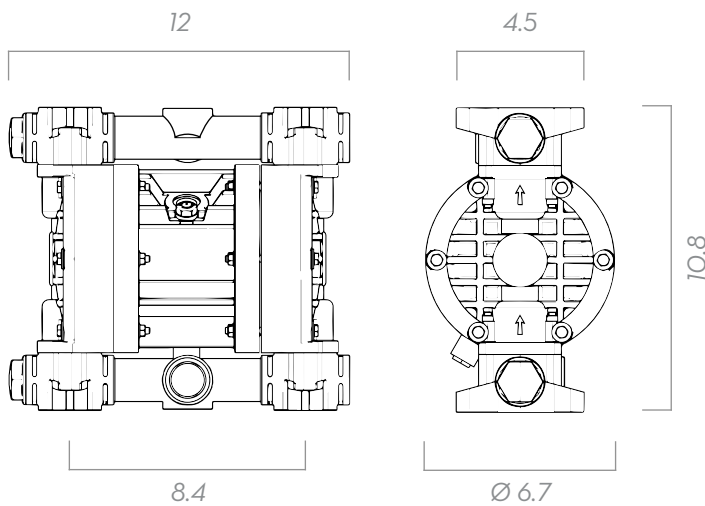

Dimensions expressed in inches

TECHNICAL DATA

PART #	DESCRIPTION	FLUIDS TYPE	PUMP BODY	IN / OUT NPT	FLOW RATE GPM	MEMBRANE TYPE	DIAPHRAGM AIR SIDE/ FLUID SIDE	BALLS	BALL SEATS*	O-RING*	INTAKE / DELIVERY CONNECTION	AIR CONNECTION	MAX SELF-PRIMING CAPACITY	MAX HEAD**	MAX AIR SUPPLY PRESSURE	MAX Ø OF PASSING SOLID
													FT	FT	PSI	IN
FOO208P50	MP140 DD AIR-OPERATED DEF PUMP 26GPM		POLYPROPYLENE	1"	26	DOUBLE	PTFE/ HYTREL	PTFE	POLYPROPYLENE	PTFE	G 1" F	G 3/8" F	20	230	101	0.16

(*) ON REQUEST WE CAN PROVIDE MEMBRANES, BALLS, BALL SEATS AND O-RINGS IN DIFFERENT MATERIALS.
 (***) THE VALUE DEPENDS ON THE CONFIGURATION OF THE PUMP